

Arduino Distance Measuring Transducer Sensor Model: AJ-SR04M User Manual



Operating Mode:

After connecting the ultrasonic ranging module with 3-5.5V power supply, the module has five working modes:

- Mode 1: Common Pulse Width Square Wave (Minimum Power Consumption 2.5mA)
- Mode 2: Low Power Pulse Width Square Wave (Minimum Power Consumption 40uA)
- Mode 3: Automatic Serial Port (Minimum Power Consumption 2.5mA)
- Mode 4: Serial Port Trigger (Minimum Power Consumption 20uA)
- Mode 5: ASCII Code output (Minimum Power Consumption 20uA)

Module Output Format Description:

* The method of switching mode. In case of power failure, the mode can be changed by changing the resistance value of R19 above the module.

* Patterns Selection Method:

1. Compatible market HR-04 trigger mode
2. Low Power Mode
3. Automatic Serial Port Mode
4. Low Power Serial Port Mode
5. Computer Printing Mode

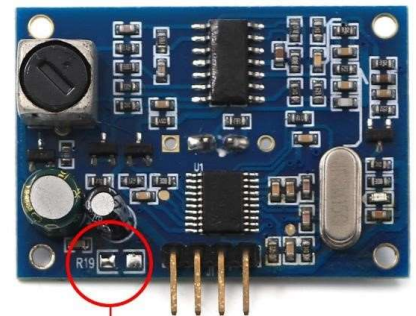

Replacement of R19 Change Mode

Pattern	Mode Corresponds	Standby Current	Low Power Current	Blind Area	The Furthest Distance
Compatible market HR-04 trigger mode	Open circuit	<2mA	-----	20cm	8m
Low Power mode	300KΩ	<2mA	<40μA	20cm	8m
Automatic Serial Port Mode	120KΩ	<2mA	-----	20cm	8m

Low Power Serial Port Mode	47K Ω	<2mA	<20 μ A	20cm	8m
Computer Printing Mode	0K Ω	<2mA	<20 μ A	20cm	8m

[Module Startup Flow Chart:](#)

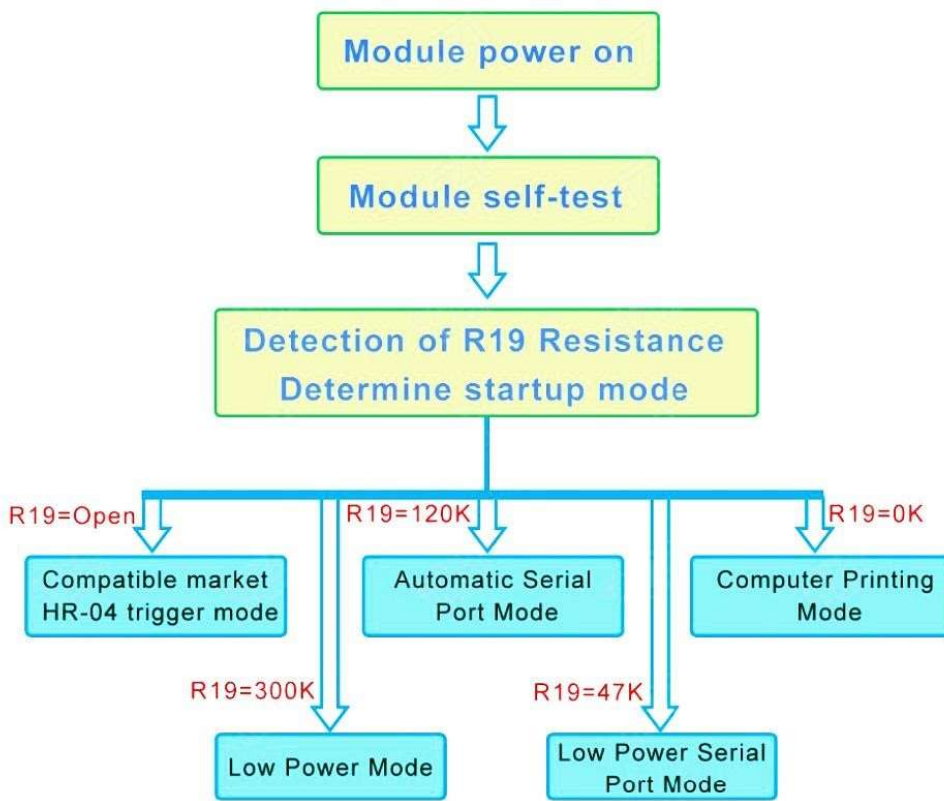

Mode 1: Standby current < 2.0mA, working current 30mA

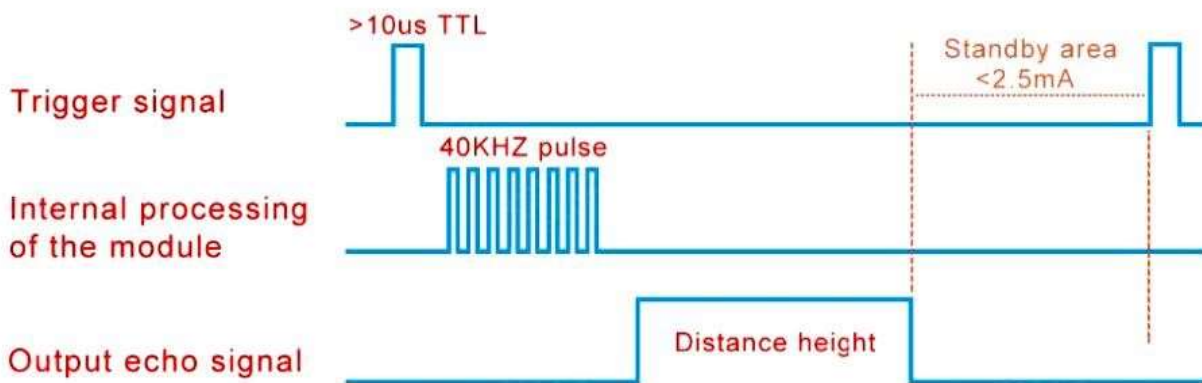

Mode 2: Low power consumption < 40uA, working current 30mA

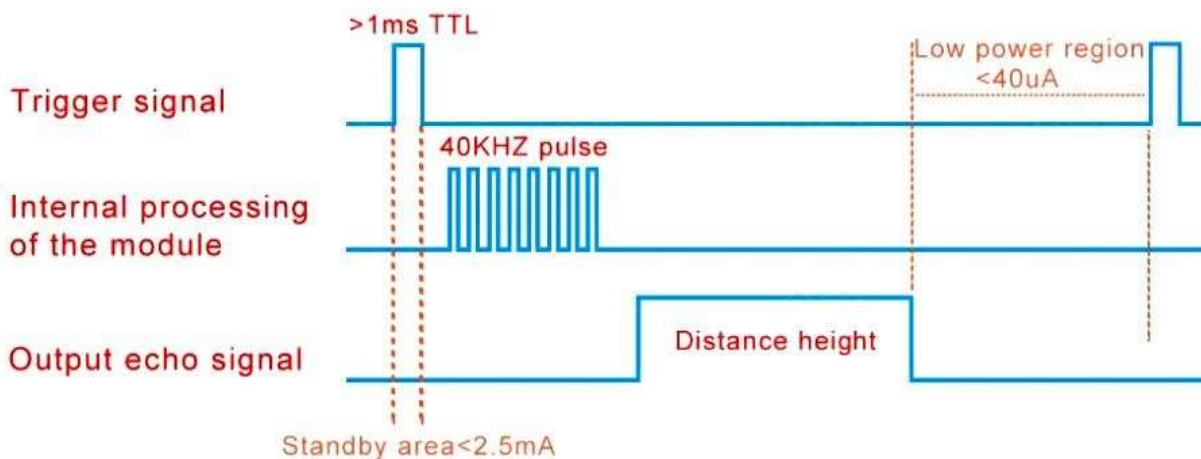

Mode 3: Serial port automatic mode, average current 5mA

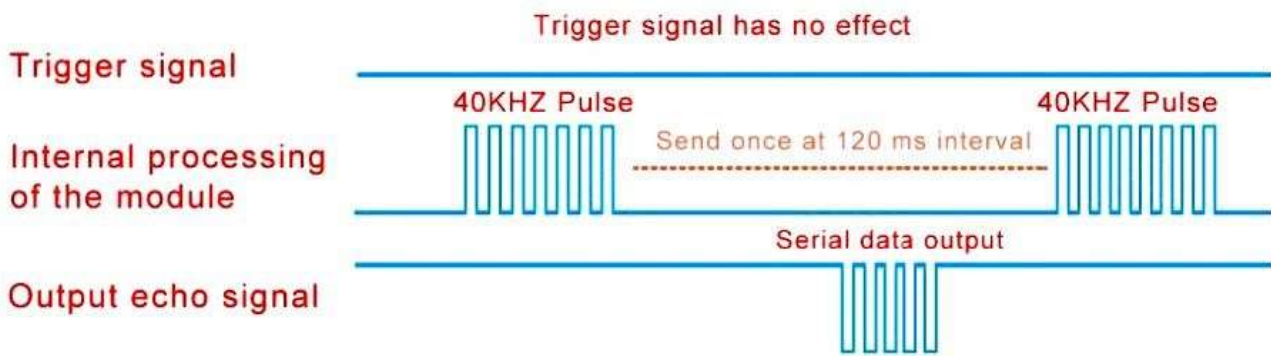

Mode 4: Serial low power mode, low power <20uA, standby 2mA

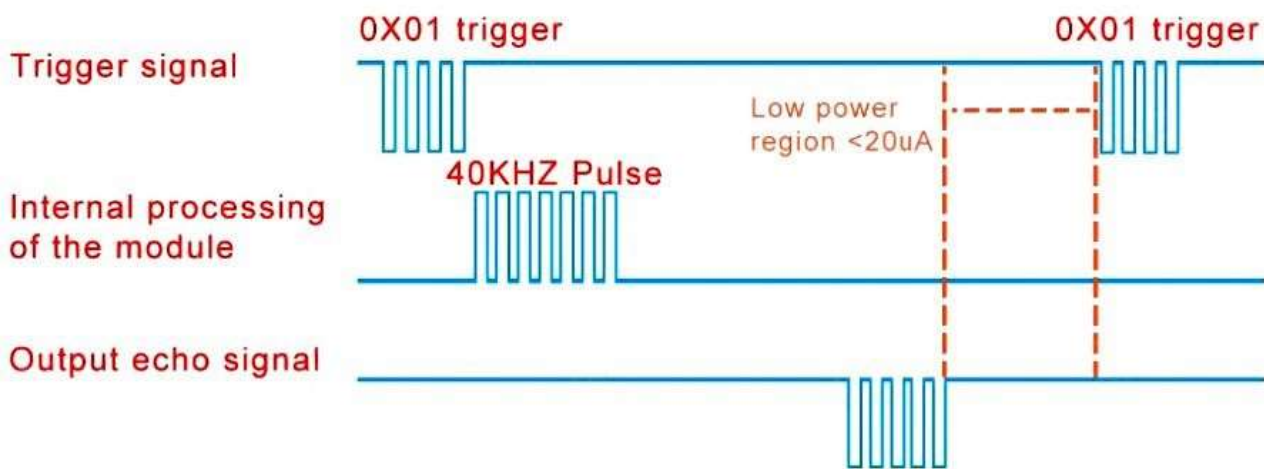

Mode 5: Serial low power mode, standby < 20uA, working 30mA

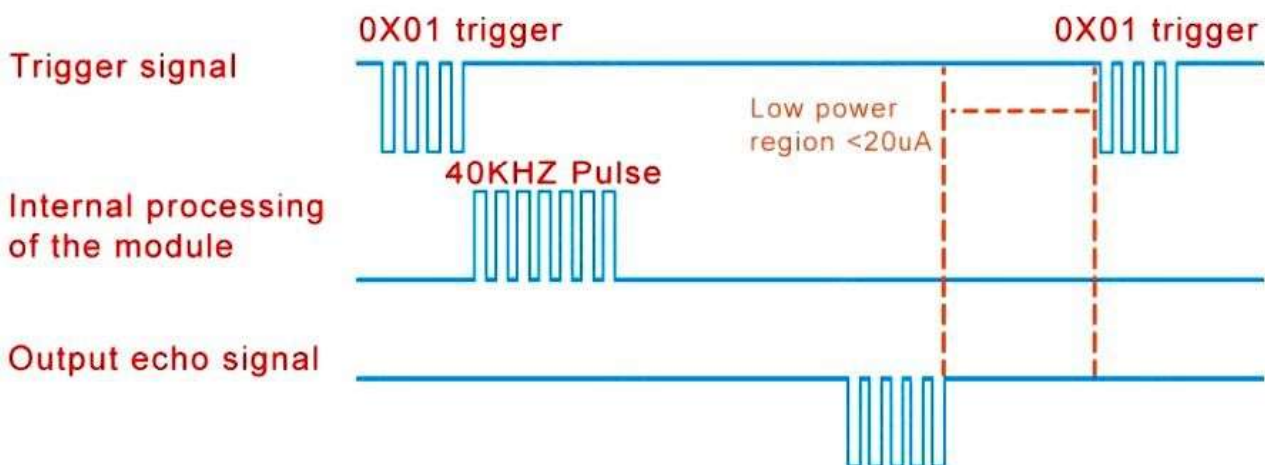

Size Chart:

Size of Strip Line Ultrasound Transducer

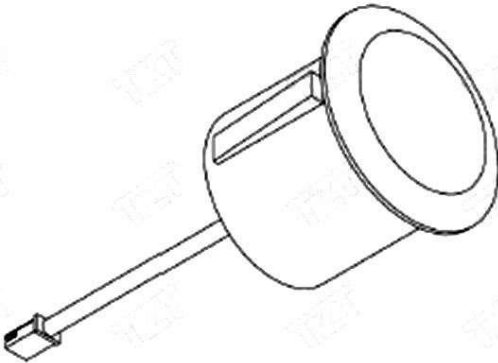
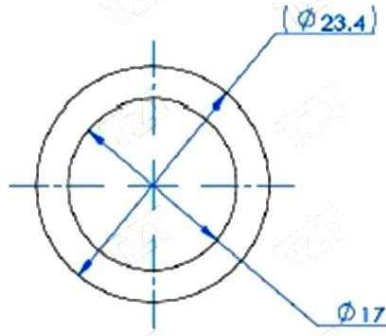
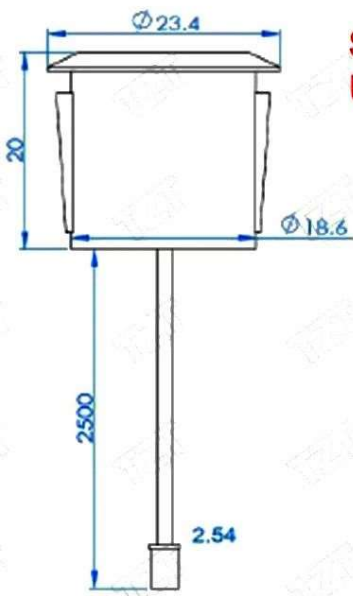

Strip control motherboard size

